

**Part Number: PT922-76110**

**Kit Contents**

Item #	Quantity Req'd.	Description
1	1	Rear Bumper Protector
2	1	Care Instructions
3		
4		
5		

**Hardware Bag Contents**

Item #	Quantity Req'd.	Description
1	N/A	
2		
3		
4		

**Additional Items Required For Installation**

Item #	Quantity Req'd.	Description
1	N/A	
2		
3		

**Conflicts**

None
------

**Recommended Tools**

<b>Personal &amp; Vehicle Protection</b>	<b>Notes</b>
Safety Glasses	
Safety Gloves	Optional
Vehicle Protection	Blankets, Part Boxes
<b>Special Tools</b>	<b>Notes</b>
Left Template	
Right Template	
Heat Gun	For installation temperatures under 60°F.
<b>Installation Tools</b>	<b>Notes</b>
Non-scratch wiping cloth	3M Micro-fiber
Masking Tape	
Roller	
<b>Special Chemicals</b>	<b>Notes</b>
Cleaner	VDC Approved Cleaner

**General Applicability**

CT 200h
---------

**Recommended Sequence of Application**







Item #	Accessory
1	Rear Bumper Protector

\*Mandatory

**Vehicle Service Parts** (may be required for reassembly)

Item #	Quantity Req'd.	Description
1	N/A	
2		
3		

**Legend**

	<b>STOP:</b> Damage to the vehicle may occur. Do not proceed until process has been complied with.
	<b>OPERATOR SAFETY:</b> Use caution to avoid risk of injury.
	<b>CAUTION:</b> A process that must be carefully observed in order to reduce the risk of damage to the accessory/vehicle and to ensure a quality installation.
	<b>TOOLS &amp; EQUIPMENT:</b> Used in Figures calls out the specific tools and equipment recommended for this process.
	<b>REVISION MARK:</b> This mark highlights a change in installation with respect to previous issue.
	<b>SAFETY TORQUE:</b> This mark indicates that torque is related to safety.

Care must be taken when installing this accessory to ensure damage does not occur to the vehicle. The installation of this accessory should follow approved guidelines to ensure a quality installation.

These guidelines can be found in the "Accessory Installation Practices" document.

This document covers such items as:-

- Vehicle Protection (use of covers and blankets, cleaning chemicals, etc.).
- Safety (eye protection, rechecking torque procedure, etc.).
- Vehicle Disassembly/Reassembly (panel removal, part storage, etc.).
- Electrical Component Disassembly/Reassembly (battery disconnection, connector removal, etc.).

Please see your Toyota dealer for a copy of this document.

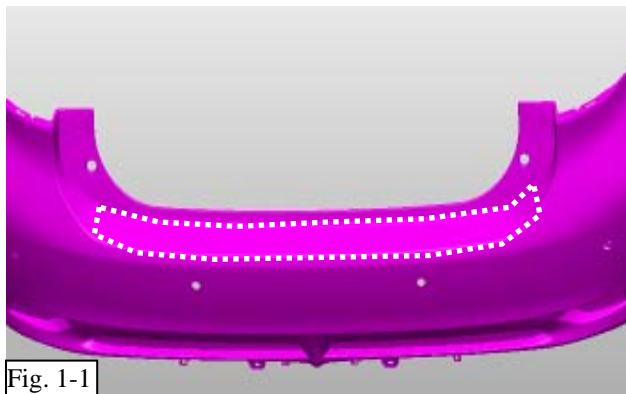

Fig. 1-1

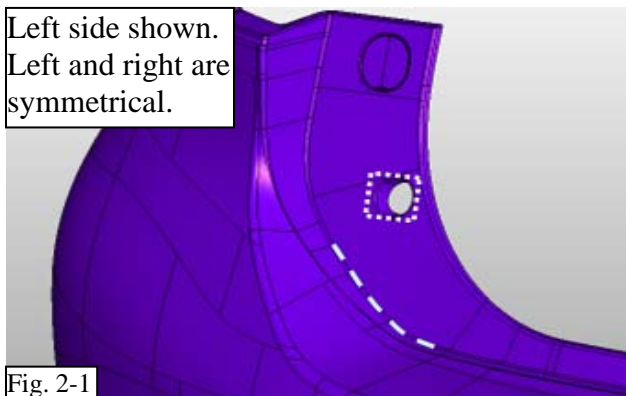

Fig. 2-1



Fig. 2-2

### 1. Preparation

- (a) Check for damaged part.
- (b) Clean the installation surface of the bumper using a VDC approved cleaner. (Fig. 1-1)

### 2. Install Rear Bumper Protector.

- (a) Attach left and right paper template on the bumper.
  - (1) Template reference hole and edges. (Fig. 2-1)
  - (2) Left paper template on page 5.
  - (3) Right paper template on page 6.
  - (4) Make sure templates are properly aligned and attached to the bumper. (Fig. 2-2)



#### (b) Installation Temperature



- (1) The rear bumper surface temperature must be between 60° F and 110° F at the time of actual installation.



**CAUTION: If necessary, a heat gun can be used to heat the part and surface to the correct installation temperature. Care must be taken to ensure the parts are not overheated. Blistering of paint, parts and or personal injury could occur.**

- (c) Install rear bumper protector (RBP).

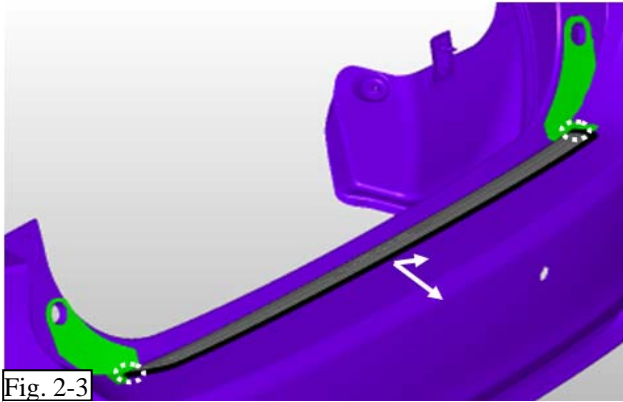

- (1) Remove tape liner.
- (2) At an angle, align corners of RBP to the left and right locating template. (Fig. 2-3)



(1) Don't let the tape side touch the bumper if not properly aligned.



(2) Make sure template sits securely and does not shift. Add more tape if needed.

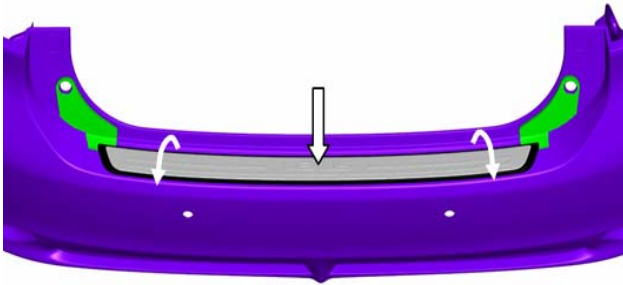

- (3) Check RBP center mark to make sure the part is not off-center.



- (4) Carefully lay the RBP flat on the bumper and secure it by firmly pressing on the center section. (Fig. 2-4)

Fig. 2-4

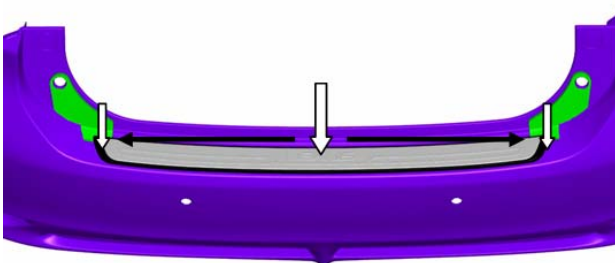

- (5) In a continuous motion, use a roller to press on the RBP firmly starting from center to half-way on one side. Do the same for the other side. (Fig 2-5).

- (1) Ensure entire surface has been pressed.

- (2) Repeat step to ensure proper attachment.

- (6) Make sure RBP is properly adhered in place and that there are no lifting or uneven gaps around the edges.

- (7) Remove the transparent protection liner on the stainless steel surface.

Fig. 2-5

### 3. Completing the installation.

- (a) Remove left and right locating template.
- (b) Wipe the area around the RBP for any smudge.

**LEXUS CT 200h 2011 - REAR BUMPER PROTECTOR**

Checklist - these points **MUST** be checked to ensure a quality installation.

<u>Check:</u>	<u>Look For:</u>
<p><u>Accessory Function Check</u></p> <ul style="list-style-type: none"><li><input type="checkbox"/> RBP Fitment</li><li><input type="checkbox"/> RBP Installation</li><li><input type="checkbox"/> Care Instructions</li></ul>	<p>There should be no uneven gaps around the edges, and clips should be securely fastened.</p> <p>RBP should not move or unbuckle when stepped on.</p> <p>Leave a copy in the glove compartment.</p>
<p><u>Vehicle Function Checks</u></p> <ul style="list-style-type: none"><li><input type="checkbox"/> Opening and closing the hatch door</li></ul>	<p>RBP should not touch any part of the hatch door.</p>
<p><u>Vehicle Appearance Check</u></p> <ul style="list-style-type: none"><li><input type="checkbox"/> After accessory installation, perform a visual inspection.</li></ul>	<p>Ensure no damage (including scuffs and scratches) was caused during the installation process. (For PPO installations, refer to TMS Accessory Quality Shipping Standard.)</p>



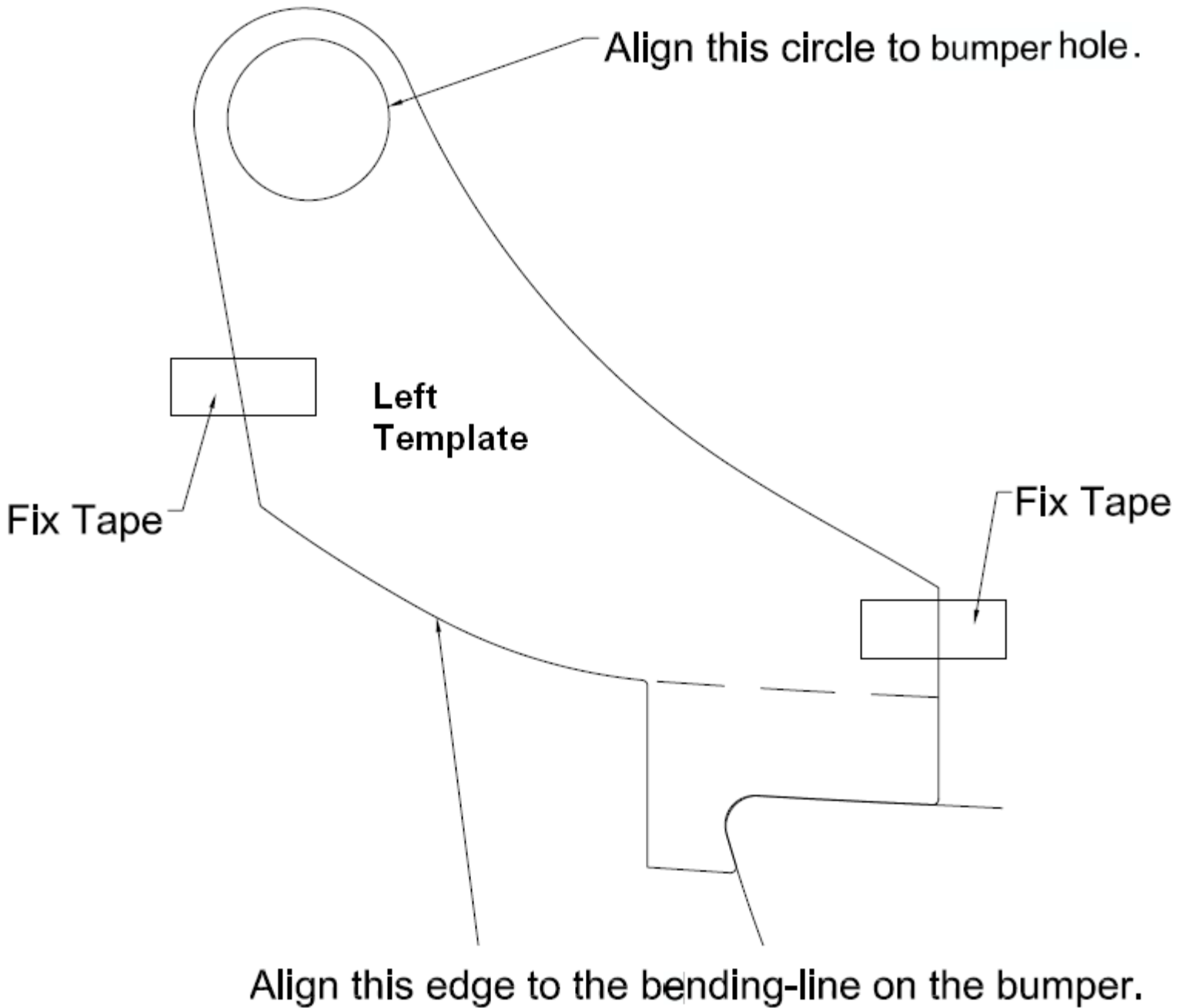

**NOTES:**

- *Cut solid lines and fold broken line*
- *Verify accuracy of printout by matching the 2" Reference dimension above.*



- *If this is a pdf document, prior to printing, set the "Page Scaling" to "None" in the Print dialogue box.*

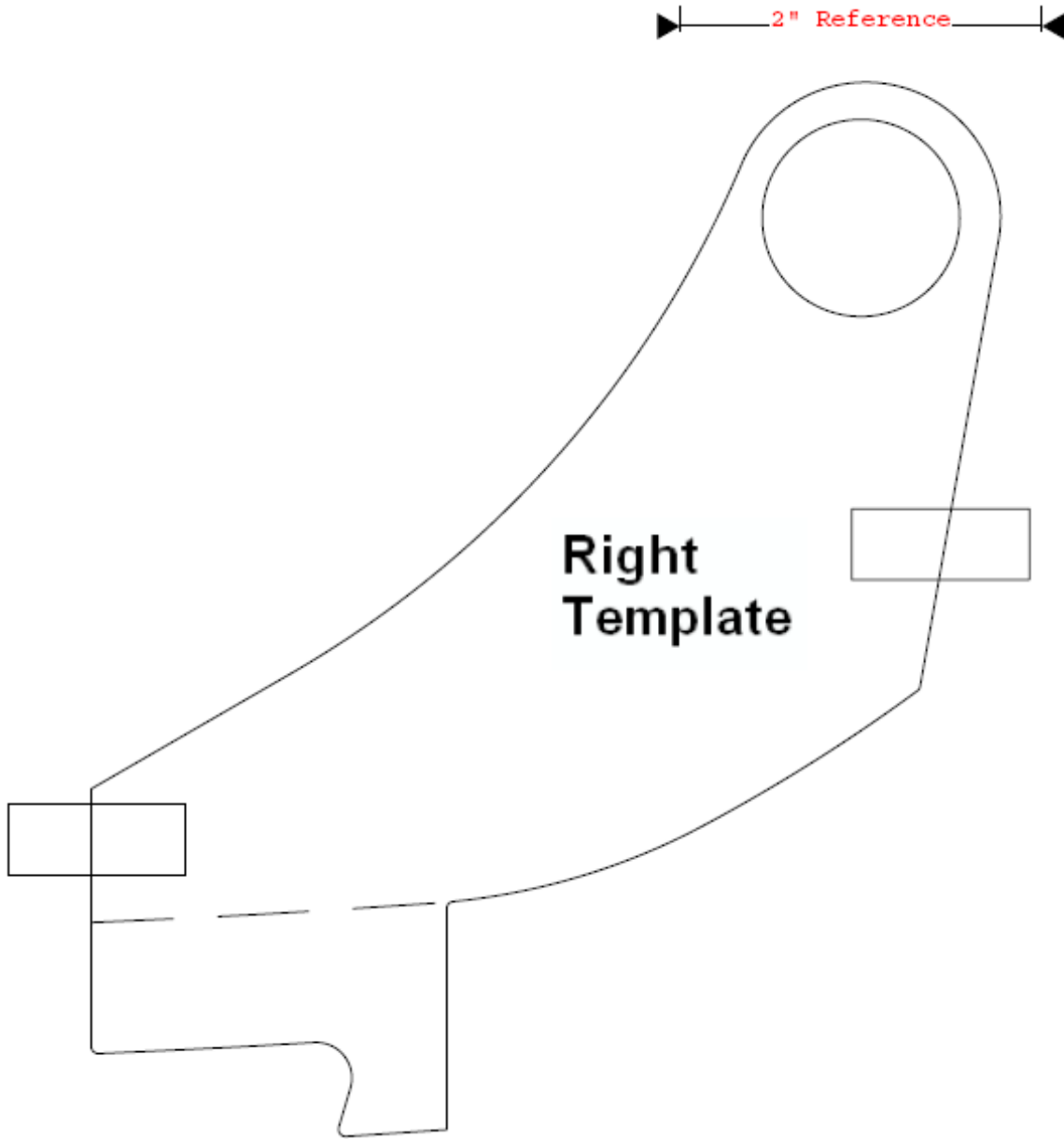

**NOTES:**

- *Cut solid lines and fold broken line*
- *Verify accuracy of printout by matching the 2" Reference dimension above.*



- *If this is a pdf document, prior to printing, set the "Page Scaling" to "None" in the Print dialogue box.*